

# Current efficiency in the chlorate cell process with an oxygen cathode (III): a gas analysis method for chlorate current efficiency

Y. BAOLIAN, Z. WENHUA\*

*Dalian Institute of Chemical Physics, Chinese Academy of Sciences, Dalian, 116012, China*

Received 8 July 1993; revised 13 October 1993

An original chlorate cell system equipped with an oxygen cathode, a DSA<sup>®</sup> and a separate reactor was set up. A method for determining the current efficiency by means of measuring the flow capacity of cell gas in the chlorate cell process has been proposed. This method is simple and convenient as well as accurate in evaluation of the chlorate current efficiency in the chlorate cell with an oxygen cathode, compared to the traditional method of analysis. The current efficiency of the anode can be estimated with the gas analysis method.

## List of symbols

$C_0, C_t$	initial or final concentration of chlorate respectively (M)	$V_{(t)}$	volume of electrolyte which cools to room temperature ( $\text{dm}^3$ )
$F$	Faraday constant ( $96\,487 \text{ As mol}^{-1}$ )	$V_i$	volumetric flow rate ( $\text{ml min}^{-1}$ )
$i$	current density ( $\text{Am}^{-2}$ )	<i>Greek symbols</i>	
$I$	constant current (A)	$\beta_j$	value of $\epsilon_a/\epsilon_j$
$M_c$	molecular weight of chlorate ( $\text{kg mol}^{-1}$ )	$\epsilon_a$	overall current efficiency for chlorate formation according to Equation 9
$P_0$	pressure at standard state (Pa)	$\epsilon_j$	differential current efficiency for chlorate formation calculated, respectively, from Equation 26 or 25
$Q_i$	loss of coulombs (As)	<i>Subscript</i>	
$t$	time (h)	$i$	$\text{O}_2$ or $\text{Cl}_2$
$T_0$	temperature at standard state (K)	$j$	A or B
$T_c, T_r$	temperature of cell or reactor ( $^\circ\text{C}$ )		
$T_s$	room temperature (K)		
$u$	linear velocity of electrolyte through the cell ( $\text{m s}^{-1}$ )		
$V_0$	volume at standard state ( $\text{m}^3 \text{ mol}^{-1}$ )		

## 1. Introduction

In an industrial chlorate cell process, mild steel is often used as cathode and  $\text{RuO}_2/\text{Ti}$  (DSA<sup>®</sup>) as anode. The overall chemical reaction in the traditional chlorate cell process can be written as

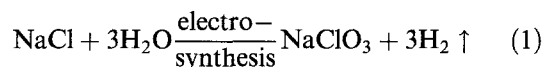

The cell voltage is 3 ~ 4 V and there are some side reactions resulting in loss of current efficiency. Electric energy is wasted in hydrogen evolution. When oxygen or air is used as a depolarizing agent, the evolution of hydrogen at the cathode surface can be suppressed and the main reaction is oxygen reduction (3). The main reactions in the chlorate cell process with a porous gas-diffusion cathode are as follows:

Anode:

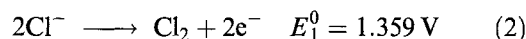

Cathode:

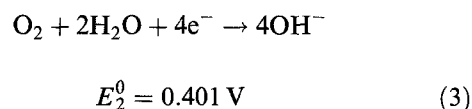

Solution:

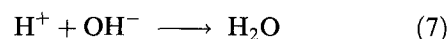
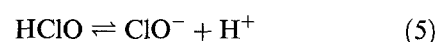
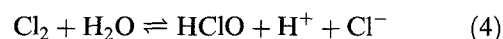

\* Author to whom correspondence should be addressed at the Institute of Chemical Metallurgy, Chinese Academy of Sciences, Beijing, 100080, China.

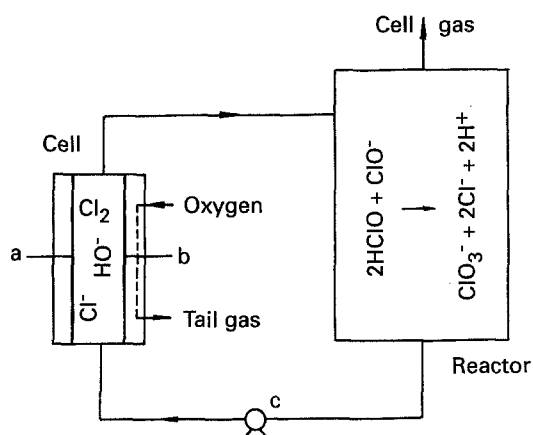
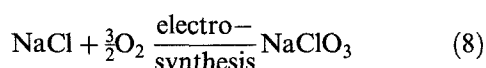

Fig. 1. Reactor system (a) anode (b) oxygen cathode (c) pump.

Overall reaction:



Thus the cell voltage may be lowered considerably with the possibility of saving 1.23 V [1]. Such an oxygen cathode approach can both eliminate the possibility of explosion and dichromate pollution and save energy.

## 2. Gas analysis method

A sketch of the chlorate cell system with an oxygen cathode is shown in Fig. 1. The active chlorine ( $\text{Cl}_2$ ,  $\text{HClO}$  and  $\text{ClO}^-$ ) is formed in the chlorate cell and then sent to the reactor in which the chemical reaction (6) takes place at a higher temperature.

### 2.1. Chemical analysis method of chlorate current efficiency

The chemical efficiency in the chlorate cell process may be formulated as follows:

$$\epsilon_a = \frac{V(t)C_t - V(0)C_0}{0.662It} M_c \quad (9)$$

The number 0.662 stands for the sodium chlorate electrochemical equivalent, where six electrons are involved in the formation of 1 molecule of  $\text{NaClO}_3$ . The current efficiency in a batch process may change with time. The rate of chlorate formation may be analysed by a chemical method and the instantaneous efficiency at constant current may be determined as follows:

$$\epsilon = \frac{V(t)}{0.662I} \left( \frac{dC_{\text{ClO}_3^-}}{dt} \right) \quad (10)$$

where  $V(t)$  and  $I$  may be assumed constant. However, in both methods it is difficult to determine the value of current efficiency.

### 2.2. Analysis of the loss of chlorate current efficiency

Side reactions at the anode may take place as

follows:

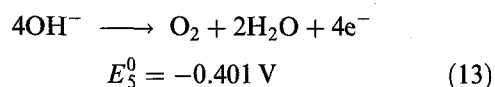
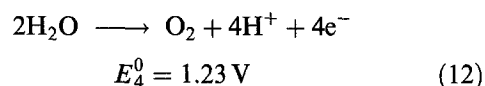
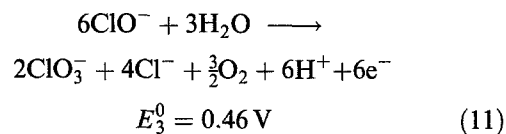

The anodic loss of current efficiency is mainly caused by the hypochlorite oxidation reaction (11) in regular conditions. When the chloride concentration is too low, the oxidation of water (12) at the anode surface may occur. If the solution becomes too alkaline, the oxidation of  $\text{OH}^-$  ions (13) at the anode surface may increase.

Side reactions at the cathode surface may occur as follows:

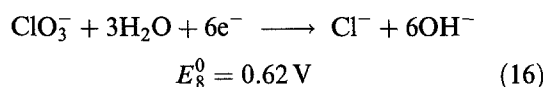
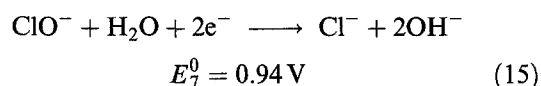
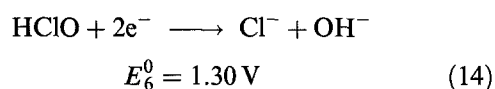

An asbestos diaphragm may be used to restrain the cathode side reactions (14 ~ 16) in the chlorate cell with an oxygen cathode, and the resultant cathode loss of current efficiency of less than one percent is negligible [2].

In electrolyte solutions, the higher temperature may accelerate the decomposition reaction of hypochlorous acid and chlorine volatilization [6, 7]. The two processes can be expressed as follows:

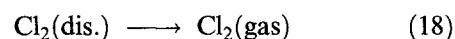
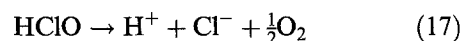

Several reactions mentioned above can evolve gases such as oxygen and chlorine. But Reactions 12, 13, 17 and 18 play a minor role with respect to the loss of current efficiency, compared to Reaction 11. However, side reactions evolving gases result in a loss of chlorate current efficiency if the cathode side reactions are neglected.

### 2.3. Gas analysis method of chlorate current efficiency

A simple way of obtaining a measure of the instantaneous current efficiency is a gas analysis method. Jaksić *et al.* [3] have given a formula for gas efficiency

in a chlorate cell with a hydrogen evolving cathode as follows:

$$\epsilon = \frac{100 - 2[\text{Cl}_2\%] - 3[\text{O}_2\%]}{100 - [\text{Cl}_2\%] - [\text{O}_2\%]} \quad (19)$$

However, the above formula does not adequately represent a chlorate cell with an oxygen cathode. Neglecting the loss of cathode, the loss of current efficiency may be divided into two parts: oxygen and molecular chlorine escaping from the solution according to the reactions above. There exist four reactions (11, 12, 13, 17) which evolve oxygen. No matter which side reactions take place at constant current,  $n$  moles evolving oxygen needs  $4nF$  coulombs in the interval  $dt$ . If the volumetric flow rate of oxygen is expressed by  $V_{\text{O}_2}^0$  at standard state and the loss of coulombs caused by the evolution of oxygen may be written by

$$dQ_{\text{O}_2} = 4FV_{\text{O}_2}^0 dt / V_0 \quad (20)$$

By the same reasoning the escaping chlorine (18) from the cell is given by

$$dQ_{\text{Cl}_2} = 2FV_{\text{Cl}_2}^0 dt / V_0 \quad (21)$$

where  $V_{\text{Cl}_2}^0$  is the volumetric flow rate of escaping chlorine at standard state. Considering the difference\* in gas volume between room temperature and standard state we may write

$$\begin{aligned} V_{\text{O}_2}^0 &= (T_0/T_s)V_{\text{O}_2} \\ V_{\text{Cl}_2}^0 &= (T_0/T_s)V_{\text{Cl}_2} \end{aligned} \quad (22)$$

The overall consumption of coulombs may be expressed as

$$dQ = Idt \quad (23)$$

And the gas current efficiency in the chlorate cell system with an oxygen cathode can be defined as follows:

$$\epsilon_B = 1 - \frac{dQ_{\text{O}_2} + dQ_{\text{Cl}_2}}{dQ} \quad (24)$$

Combining Equations 20 to 23 with Equation 24 the expression for gas current efficiency is

$$\epsilon_B = 1 - \frac{2F}{I} \left( \frac{T_0}{T_s} \right) \left( \frac{2V_{\text{O}_2} + V_{\text{Cl}_2}}{V_0} \right) \quad (25)$$

If the volumetric flow rate of chlorine is small, a simple equation may be obtained as follows

$$\epsilon_A = 1 - 78.4 \frac{V_{\text{O}_2}(\text{ml min}^{-1})}{I(\text{A})T_s(\text{K})} \quad (26)$$

Owing to the more direct and accurate measurement for the flow capacity of cell gas, Equations 25 and 26 are easier than Equations 9 and 10 when the current efficiency has to be determined in the electrolyte system with an oxygen cathode.

\* Gas temperature in the bubble meter is identical to room temperature when the gas volumetric flow rate is lower than  $15 \text{ ml min}^{-1}$ .

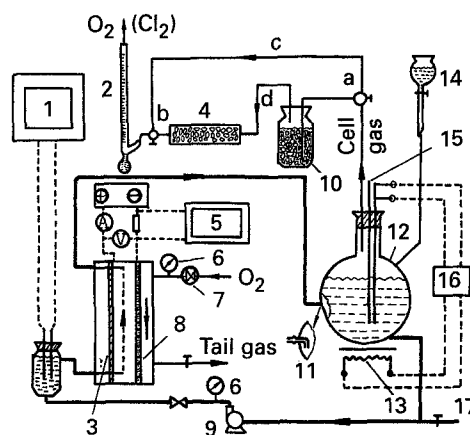

Fig. 2. Apparatus for gas current efficiency determination in a chlorate cell with an oxygen cathode. (1) pH meter, (2) soap bubble meter, (3) DSA<sup>®</sup>, (4) drying tube, (5) ampere-hour meter, (6) pressure gauge, (7) gas flow control valve, (8) oxygen cathode, (9) magnetic pump, (10) gas wash bottle (20% KI) with ceramic rings, (11) automatic stirring tube of horizontal bend, (12) chemical reactor, (13) electric heater, (14) feeder for addition of dilute HCl or NaOH, (15) thermometer, (16) temperature controller, and (17) electrolyte entrance or outlet.

### 3. Experimental details

The experimental apparatus is shown in Fig. 2. The total volume of electrolyte in the cell system was  $1.2 \text{ dm}^3$ . The laboratory cell was equipped with an oxygen cathode, a DSA<sup>®</sup> (dimensionally stable anode) and a separate reactor. All materials of construction in the cell were either glass, rubber or PVC. The anode to cathode spacing was approximately 5 mm. The electrolyte was recirculated through the cell with a magnetic pump (CXB-30) whose outlet pressure was about 0.02 MPa. The flow rate of the electrolyte was  $3.85 \times 10^{-5} \text{ m}^3 \text{ s}^{-1}$  and the linear velocity of electrolyte through the cell was  $0.23 \text{ m s}^{-1}$ .

The oxygen cathode was made of Teflon, active carbon, a nickel screen and appropriate electrocatalysts. The temperatures in the cell and reactor were almost identical and the pH was maintained constant at  $\pm 0.1$  pH unit. It was relatively steady when the chlorate cell was equipped with an oxygen cathode [2].

At constant current, the flow rate of cell gas was measured by a soap bubble meter. The cell gas was

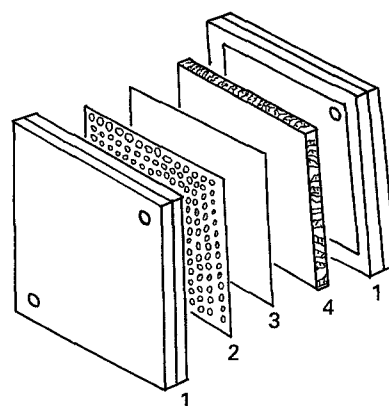

Fig. 3. Schematic construction of the electrolyte cell. (1) Plank frame, (2) DSA<sup>®</sup>, (3) asbestos diaphragm, (4) porous gas-diffusion cathode.

Table 1. Chlorate efficiency by the gas and chemical analysis methods

	[NaCl]200 ~ 300			pH 6.5			[NaCl]300/g dm <sup>-3</sup>				[NaCl]200 ~ 300			
	/g dm <sup>-3</sup> , pH 6.5										/g dm <sup>-3</sup> , pH 6.5			
	t/h			[NaCl]/g dm <sup>-3</sup>			pH				*[NaClO <sub>3</sub> ]/g dm <sup>-3</sup>			
DSA-1	2.1	4.7	7.2	50	150	300	6.0	6.5	7.2	8.0	16	102	205	300
V <sub>O<sub>2</sub></sub> †	4.22	3.90	3.46	8.56	4.73	3.90	4.11	3.95	4.56	10.77	4.22	3.91	3.12	3.12
V <sub>Cl<sub>2</sub></sub> †	0.59	0.95	0.99	0.58	0.57	0.95	1.83	0.95	0.23	0.38	0.59	0.36	0.31	0.18
ε <sub>A</sub> /%	91.8	92.4	93.3	83.4	90.8	92.4	92.0	92.4	91.2	79.1	91.8	92.4	94.0	94.0
ε <sub>B</sub> /%	91.2	91.9	92.3	82.8	90.3	91.9	90.3	91.9	90.9	78.8	91.2	92.1	93.7	93.8
ε <sub>a</sub> /%	88.9	89.6	90.9	80.7	88.0	89.6	87.1	89.6	89.5	80.9	89.2	90.1	91.6	91.7
β <sub>A</sub>	0.968	0.970	0.974	0.968	0.969	0.970	0.947	0.970	0.981	1.02	—	—	—	—
β <sub>B</sub>	0.975	0.975	0.985	0.975	0.975	0.975	0.965	0.975	0.985	1.03	—	—	—	—

	t/h			[NaCl]/g dm <sup>-3</sup>			pH				*[NaClO <sub>3</sub> ]/g dm <sup>-3</sup>				
	2.2	4.1	6.1	7.9	65	100	200	300	6.0	6.5	7.0	8.0	20	150	300
DSA-2	2.2	4.1	6.1	7.9	65	100	200	300	6.0	6.5	7.0	8.0	20	150	300
V <sub>O<sub>2</sub></sub> †	3.22	3.35	3.65	3.61	5.18	3.79	3.22	2.77	4.18	3.22	3.27	9.13	3.22	2.74	2.56
V <sub>Cl<sub>2</sub></sub> †	0.17	0.11	0.18	0.29	0.32	0.23	0.17	0.40	0.96	0.17	0.34	0.19	0.17	0.13	0.11
ε <sub>A</sub> /%	93.8	93.5	93.0	93.0	90.0	92.7	93.8	94.6	91.9	93.8	93.7	82.3	93.8	94.7	95.0
ε <sub>B</sub> /%	93.6	93.4	92.8	92.8	89.7	92.4	93.6	94.2	91.0	93.6	93.3	82.1	93.6	94.6	94.9
ε <sub>a</sub> /%	91.3	90.1	91.4	90.5	89.3	90.1	91.3	91.8	87.8	91.3	91.0	80.0	91.5	92.5	92.8
β <sub>A</sub>	0.973	0.964	0.983	0.973	0.992	0.972	0.973	0.970	0.955	0.973	0.971	0.972	—	—	—
β <sub>B</sub>	0.975	0.965	0.985	0.975	0.996	0.975	0.975	0.975	0.965	0.975	0.975	0.975	—	—	—

\* The chemical efficiency  $\epsilon_a$  in the varied concentration of chlorate is calculated by Equation 29,  $T_s = 291$  K.

†  $V_{O_2}$ ,  $V_{Cl_2}$  in ml min<sup>-1</sup>.

bubbled through 20% KI to remove traces of chlorine and then passed through a drying tube. The remaining gas was oxygen (Fig. 2). The cell was generally operated for two to four hours at a current density of 1000 A m<sup>-2</sup> until steady-state cell gas was obtained.

A sketch of the chlorate cell is shown in Fig. 3. Two different kinds of anodes were used in the experiment. DSA<sup>®</sup>-1 (provided by Factory 724 of Shenyang) was more active and produced more oxygen than DSA<sup>®</sup>-2 (provided by Factory 4805 of Shanghai). The electrode area was 140 cm<sup>2</sup>.

The electrolyte was periodically sampled during each experiment. The concentration of hypochlorite was determined by iodometric titration. The chloride

concentration was determined by titration with an AgNO<sub>3</sub> standard solution and indicator K<sub>2</sub>CrO<sub>4</sub>. The concentration of chlorate was determined by self oxidation to the excessive FeSO<sub>4</sub> and back titration with KMnO<sub>4</sub> solution. Here FeSO<sub>4</sub> solution was used as a reducing agent. The volumetric flow rate of cell gas was measured by bubble meter.

#### 4. Results and discussion

##### 4.1. Comparison of current efficiency between the chemical and gas analysis method

The chemical current efficiency was obtained by Equation 9 and the gas efficiency by Equations 25

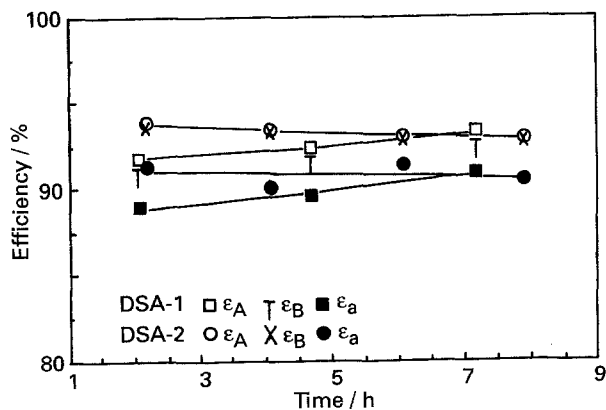

Fig. 4. Comparison of curves of current efficiency as a function of time [NaCl] 200 ~ 300 g dm<sup>-3</sup>,  $i = 1000$  A m<sup>-2</sup>,  $T_c = T_r = 60^\circ$  C, pH 6.5,  $u = 0.23$  m s<sup>-1</sup>.

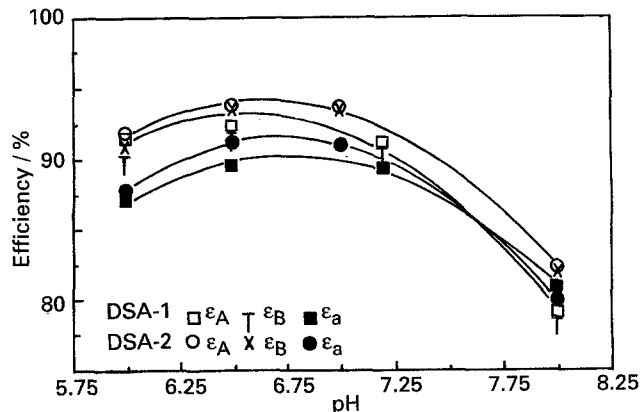

Fig. 5. Curves of current efficiency at different pH values [NaCl] 300 g dm<sup>-3</sup>,  $i = 1000$  A m<sup>-2</sup>,  $T_c = T_r = 60^\circ$  C,  $u = 0.23$  m s<sup>-1</sup>.

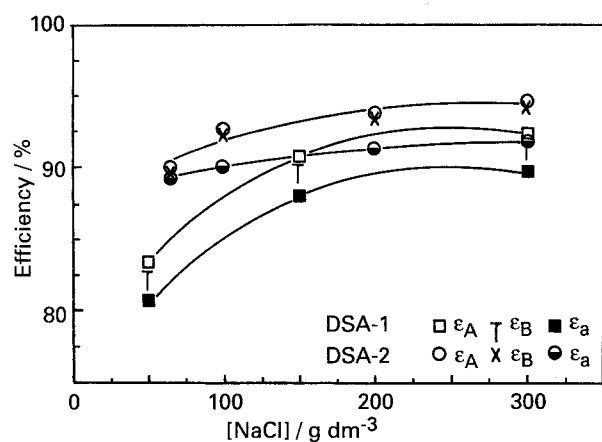

Fig. 6. Current efficiency curves as a function of chloride concentration  $i = 1000 \text{ A m}^{-2}$ ,  $T_c = T_r = 60^\circ \text{ C}$ ,  $\text{pH } 6.5$ ,  $u = 0.23 \text{ m s}^{-1}$ .

and 26. The experimental data are found in Table 1. The comparative experiments were operated for different times and concentrations of chloride as well as pH to verify the identical results between the gas and chemical efficiency (Figs 4–6). From Table 1 for DSA<sup>®</sup>-1,  $[\text{NaCl}] = 200 \sim 300 \text{ g dm}^{-3}$ ,  $\text{pH} = 6.5$ , the average efficiency for chlorate formation is 0.889 for the period  $0 \sim 2.1 \text{ h}$ , 0.896 for the period  $2.1 \sim 4.7 \text{ h}$ , and 0.909 for the period  $4.7 \sim 7.2 \text{ h}$ . Comparing these results with  $\epsilon_B$  for these periods, it can be concluded that both results agree. In particular the pilot plant experiments proved that  $\epsilon_a$  was almost equal to  $\epsilon_A$ , which will be discussed in a future paper.

#### 4.2. Effect of chlorine loss on current efficiency

The water vapour in the cell gas was small because room temperature was about  $291 \sim 295 \text{ K}$  and the flow rate of cell gas was not large. It is possible to consider that the cell gas through the tube ( $a \rightarrow c \rightarrow b$ ) (Fig. 2) was the sum of oxygen and chlorine [4]. The value of the ratio of chemical efficiency to gas current efficiency may be defined as follows

$$\beta_j = \epsilon_a / \epsilon_j \quad (j = A, B) \quad (27)$$

Then  $\bar{\beta}_j$  can be obtained from the following equation

$$\left. \begin{aligned} \bar{\beta}_A &= \frac{1}{n} \sum (\beta_A)_i = 0.973 \\ \bar{\beta}_B &= \frac{1}{n} \sum (\beta_B)_i = 0.978 \end{aligned} \right\} \quad (28)$$

Table 2. Effects of foreign additives on gas efficiency

[NaCl] / g dm <sup>-3</sup>	200			50			Conditions
	$\epsilon_{(\text{O}_2)} / \%$			$\epsilon_{(\text{O}_2)} / \%$			
Buffer / g dm <sup>-3</sup>	Na <sub>2</sub> HPO <sub>4</sub>	Na <sub>2</sub> Cr <sub>2</sub> O <sub>7</sub>	NaF	Na <sub>2</sub> HPO <sub>4</sub>	Na <sub>2</sub> Cr <sub>2</sub> O <sub>7</sub>	NaF	DSA-2
0	94.1	93.8	93.9	89.9	89.9	89.5	$i = 1000 \text{ A m}^{-2}$
1	93.6	94.1	94.8	89.9	89.0	92.2	$T_c = T_r = 60^\circ \text{ C}$
3	93.5	94.6	95.0	89.6	89.6	92.6	$u = 0.23 \text{ m s}^{-1}$
5	93.6	94.8	95.0	89.4	89.6	92.1	$\text{pH } 6.7$
7	93.5	94.8	94.8	89.6	89.7	92.2	$T_s = 295 \text{ K}$

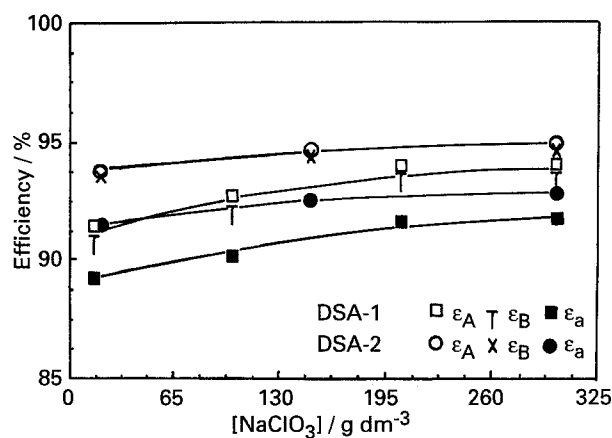

Fig. 7. Gas efficiency (experimental data) and chemical efficiency (Calculated values) as a function of chlorate concentration  $[\text{NaCl}] 200 \sim 300 \text{ g dm}^{-3}$ ,  $\text{pH } 6.5$ ,  $i = 1000 \text{ A m}^{-2}$ ,  $T_c = T_r = 60^\circ \text{ C}$ ,  $u = 0.23 \text{ m s}^{-1}$ .

The difference between  $\bar{\beta}_A$  and  $\bar{\beta}_B$  is only 0.5% and hence the effect of escaping chlorine may be neglected.

#### 4.3. Error analysis for the two kinds of current efficiency

It seems, generally, that  $\epsilon_A$  and  $\epsilon_B$  are systematically higher than  $\epsilon_a$ , and also that  $\epsilon_a$  remains practically constant over a long period [5]. From Figs 4–6, there is clearly a discrepancy between the gas current efficiency  $\epsilon_B$  and the chemical efficiency  $\epsilon_a$ . The causes of the error may be (i) the electrolyte is inclined to alkalinity when the system starts to operate; (ii) partial acidity of the electrolyte may be higher than other places in the course of adjusting pH values, which may temporarily result in the decomposition of active chlorine; (iii) the active chlorine may oxidize organic substances in the system and the cathode loss of efficiency has been neglected. It is likely that the reduction of hypochlorite occurs at the cathode especially at the beginning of system operation. Therefore, chemical efficiency,  $\epsilon_a$ , is an average efficiency over a period of time and always lower than the steady-state gas current efficiency  $\epsilon_A$  or  $\epsilon_B$ .

Since the value of  $\bar{\beta}_j$ , which varies from 0.973 to 0.978, is approximately 1.0, the gas efficiency may be considered to be identical with the chemical efficiency when current efficiency for chlorate formation needs to be determined.

#### 4.4. Current efficiency in concentrated chlorate and performance of anode

When the chlorate cell system is operated for a short time or over several hours, the error of chemical analysis is larger and the current efficiency may be distorted in the high concentration chlorate because the formation of chlorate is too small to compare with the chlorate in the solutions. The results suggest that the chemical efficiency may be evaluated by the gas analysis method. By Equation 27 we may substitute  $\bar{\beta}_j$  for  $\beta_j$  and obtain

$$\epsilon_a = \bar{\beta}_j \epsilon_j \quad (j = A, B) \quad (29)$$

where  $\bar{\beta}_A = 0.973$ ,  $\bar{\beta}_B = 0.978$ ,  $\epsilon_A$  or  $\epsilon_B$  may be determined by Equations 26 or 25. Hence the chemical efficiency in the concentrated chlorate can be determined by the gas analysis method (Fig. 7).

From Figs 4–7 the current efficiency of anode DSA<sup>®</sup>-2 is slightly higher than that of anode DSA<sup>®</sup>-1. Not considering the decomposition of active chlorine (HClO) and neglecting the molecular chlorine in the cell gas, as well as the cathode loss of efficiency, the gas current efficiency,  $\epsilon_B$ , is identical with the instantaneous efficiency of the anode. Therefore the electrochemical performance of the anode may be estimated by the gas analysis method.

#### 4.5. Application of the gas analysis method

The current efficiency in the chlorate cell process with an oxygen cathode can be approximately determined by measuring the flow capacity of oxygen. Useful results in different conditions can be easily obtained by the gas method. Although the new-type chlorate

cell system needs no addition of dichromate, the action of foreign salts to the process (Table 2) can also be investigated.

### 5. Conclusions

The current efficiency in a chlorate cell with an oxygen cathode can be determined by measuring the cell gas in the recycling electrolyte. The results of the gas method are identical with those of chemical analysis. This constitutes a simple and convenient to examine chlorate current efficiency. This method is useful in the investigation of electrochemical problems in high concentration chlorate and be useful for assessment of electrocatalytic performance of anode materials.

### Acknowledgements

The authors thank Associate Prof. Anna Maria Barnum for reading the manuscript and Dr Xia Haiping for providing discussion.

### References

- [1] Y. Baolian, *J. Chem. Ind. & Eng. (Eng.)* **2** (1987) 227.
- [2] Y. Baolian, *J. Chem. Ind. & Eng. (China)* **40** (1989) 606.
- [3] M.M. Jaksic, A.R. Despic, I.M. Sonka and B.Z. Nikolic, *J. Electrochem. Soc.* **116** (1969) 1316.
- [4] Z. Wenhua, Dissertation, Dalian Institute of Chemical Physics, Chinese Academy of Sciences (1992).
- [5] Z. Wenhua and Y. Baolian, *J. Chem. Ind. & Eng. (China)* **44** (1993) 395.
- [6] N. Ibl and H. Vogt, 'Comprehensive Treatise of Electrochemistry', Vol. 2, Plenum Press, New York (1981) p. 167.
- [7] K.L. Hardee and L.K. Michell, *J. Electrochem. Soc.* **136** (1989) 3314.